

Investigating Pointing Tasks across Angularly Coupled Display Areas

Fabian Hennecke¹, Alexander De Luca², Ngo Dieu Huong Nguyen¹,
Sebastian Boring³, and Andreas Butz¹

¹ HCI Group / ² Media Informatics Group
University of Munich (LMU)

Amalienstr. 17, 80333 Munich, Germany

³ University of Copenhagen, DIKU

Njalsgade 128, Copenhagen S, Denmark

{fabian.hennecke, alexander.deluca, andreas.butz}@ifi.lmu.de,
nguyenn@cip.ifi.lmu.de, sebastian.boring@diku.dk

Abstract. Pointing tasks are a crucial part of today's graphical user interfaces. They are well understood for flat displays and most prominently are modeled through Fitts' Law. For novel displays (e.g., curved displays with multi-purpose areas), however, it remains unclear whether such models for predicting user performance still hold – in particular when pointing is performed across differently oriented areas. To answer this question, we conducted an experiment on an angularly coupled display – the *Curve* – with two input conditions: direct touch and indirect mouse pointer. Our findings show that the target position affects overall pointing speed and offset in both conditions. However, we also found that Fitts' Law can in fact still be used to predict performance as on flat displays. Our results help designers to optimize user interfaces on angularly coupled displays when pointing tasks are involved.

Keywords: Pointing, Fitts' law, display orientation, curved surface.

1 Introduction

Since the commercialization of the WIMP paradigm (Windows, Icons, Menus, Pointer), pointing has become the fundamental interaction technique for a variety of displays – either through pointing devices or more recently through direct touch. The abundance of different input technologies and display types turned pointing on a flat display into a widely researched field. In his original experiment, Fitts [1] studied direct pointing at physical objects. MacKenzie et al. [5] and others looked at indirect pointing and confirmed that Fitts' Law – while not intended for such scenarios – is still applicable to different input techniques. However, they could show that different input devices heavily affect a user's pointing performance.

As interactive surfaces with different sizes and orientations (e.g., tables, walls, etc.) have become more and more commonplace since the DigitalDesk [14], recent pointing experiments focused on such displays. Although these displays still allow indirect pointer input, they also provide the possibility of direct touch. For large horizontal

surfaces (e.g., tabletops), several experiments revealed that a Fitts'-related formula still describes this type of interaction well [6,10]. Po et al. [9] demonstrated the predictability of input performance also on large vertical displays. While pointing tasks on horizontal or vertical screens are well understood individually, as of today it is unclear whether those results will hold for pointing across a combination of such displays as the display's orientation influences the precision of direct pointing [2]. Nacenti et al. [7] found that gaps between displays in multi-display environments influence indirect pointing performance. Recently developed displays like the Curve and BendDesk aim to seamlessly combine horizontal and vertical displays into a single, curved screen [13,15] and allow for mouse and touch input. Studies already revealed an influence on dragging and flicking across the display connection [3,12].

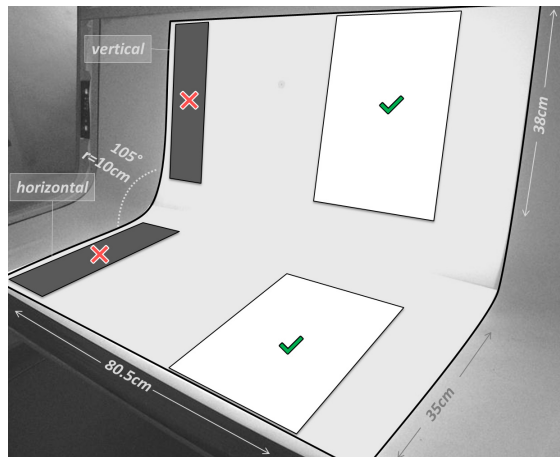

Fig. 1. Pointing performance: central target areas (white) performed best and outer areas (grey) performed worst in terms of task completion time for touch and pointer

Beside those already known effects, such novel displays introduce a series of challenges for pointing tasks: a change of pointer perception during display transition [8], oblique touch and viewing angles [2], and different finger and arm movements compared to a hypothetical planar, angular displays. They also introduce different pointing distances between targets on different display areas with regard to the input modality: while the cursor has to cross the display surface, the user's finger can use a midair shortcut (i.e., a more direct way). Since pointing is extremely important in current user interfaces, it is vital to understand how these effects influence pointing and whether or not there are different sweet spots for pointing depending on the input modality.

We conducted an experiment to identify the influence of angularly coupled display areas on generic pointing tasks. We used two input modalities – direct touch and indirect mouse pointer – in a Fitts'-like task design. In this paper, we present the study design and its results, which are a first step towards a deeper understanding of the placement of interactive elements with regards to the input modality. While the best

position for a pointer-sensitive button is in a corner of the display (e.g., Start-Button in former Windows versions), it is different for touch-sensitive areas. While the handedness of a user already narrows down the choice of potentially good areas, it still remains unclear where these areas are exactly for a given input modality.

2 Evaluation

To better understand the main influences of angularly coupled display areas, we focused on three main research questions: (RQ1) does pointing performance vary for different display areas in terms of time and offset? (RQ2) Does the target's position affect the user's subjective perception of pointing performance? (RQ3) Can pointing time be predicted based on the target's position and its size?

2.1 Apparatus, Design and Participants

We conducted our experiment on the Curve display (see Figure 1), whose design is ergonomically optimized as shown by Wimmer et al. [15]. It contains two HD projectors for high-resolution output and four PointGrey FireflyMV cameras for touch input. With both the projections as well as the tracking cameras overlapping, the output resolution is 60 dpi (tracking resolution: 14 dpi). An 800 dpi optical laser mouse with standard Windows 7 cursor properties (e.g., acceleration) was used for pointer input.

MacKenzie et al. [4] described the problem of participants entering targets at an angle and thus increased the width of these two-dimensional targets. To overcome this, we used circular targets and varied their diameter. We only investigated tasks along the vertical axes to avoid effects of the crossing angle on user performance and perception [12]. In order to cover the height of both display areas we also varied the distance between the starting points and the targets.

We conducted two experiments with different input conditions: touch and pointer input. Within each experiment, we used a repeated measures design. We varied the horizontal position of the target area (six different axes, spaced 269 px (11.5 cm) apart from each other), the size of the target areas (diameter: 40 px (1.7 cm), 54 px (2.3 cm), 70 px (3.0 cm), and 91 px (3.9 cm)), the distance between start button and target area along the surface (402 px (17.2 cm), 810 px (34.6 cm), 1212 px (51.8 cm), and 1616 px (69.1 cm)), and the direction along the axis (upwards, downwards) as within-subject variables (see Figure 2). We decided to use the surface distance as this considers the midair shortcut in the touch condition as a special capability of the input technique. The order of the axes was counterbalanced using a Latin square and all other factors were randomized per participant. Each participant had to complete two blocks of 192 trials each ($6 \times 4 \times 4 \times 2$).

We recruited 30 participants per experiment, none of which participated in both experiments (touch: 22 male, 8 female; body-height: 159 cm – 194 cm; pointer: 22 male, 8 female; body-height: 155 cm – 194 cm), 27 being right-handed in the touch- and 24 in the pointer-input experiment.

2.2 Task and Procedure

Each participant was seated centrally in front of the display. Before the experiment began, participants familiarized themselves in a training phase with 20 random pointing tasks, which were similar to those used in the actual experiment. Participants were allowed to use the hand of their choice for input.

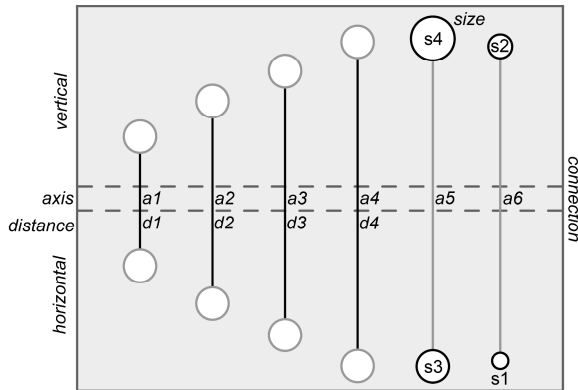

Fig. 2. Task Layout with the within-subject factors: 6 axes, 4 distances and 4 target sizes resulting in 192 trials as pointing was done in both directions (upwards and downwards)

The participants of the touch-input experiment were further equipped with a small marker (weight: 4 grams) on their input finger. A camera kept track of the marker movement to gather information on how they bridged the distance between both display areas. In both conditions, participants first had to press a start button on one end of an axis and then aim for the target area (see Figure 2) without feedback about pointing performance. Afterwards, all participants completed a questionnaire.

2.3 Measures

We measured: (1) Task completion time (TCT) as the time between the lift-off event within the start button (finger lift-off, button release) and the first recognition of an event within the target (touch recognition, mouse button down; and (2), the Pointing offset (PO) as the distance between the center of the target and the center of the participants' input (center of touch, pointer position) without correcting for touch perception or pointer movement in the display's connection.

To assess the participants' own perception of their performance and possible fatigue, we used a self-assessment questionnaire with 5-point Likert scales.

2.4 Statistical Tests and Analysis

We used the first set of each session (192 trials) for our analysis except for analyzing fatigue, as the repetition did not have any effect on the results. Additionally, we did not take any targeting errors (participant does not hit the target) into account, as they

were too few to have an influence at all. If not stated otherwise, we used an Axes \times Distance \times Size \times Direction ($6 \times 4 \times 4 \times 2$) repeated measures analysis of variance (ANOVA).

3 Results

In the pointer input experiment, we had to remove two participants due to corrupted log files. In cases in which the assumption of sphericity was violated, we applied Greenhouse-Geisser corrections.

3.1 Task Completion Time

Touch. We found significant main effects for the target's Size ($F_{3,87} = 41.08$, $p < .001$), and the target's Distance ($F_{2,281,66,146} = 114.86$, $p < .001$). The factor Axes also showed a significant main effect ($F_{5,145} = 2.31$, $p < .05$) with axis 4 ($M = 817$ ms) and axis 5 ($M = 803$ ms) being the best, and axis 1 ($M = 851$ ms) the worst. Looking at the participants' handedness revealed only a small influence on the TCT. Interestingly, the task's Direction also showed a significant main effect ($F_{1,29} = 8.484$, $p < .05$) with downward pointing being on average 4% (36ms) faster than pointing upwards. We also found significant interaction effects for Distance \times Size ($F_{6,244,181,08} = 2.18$, $p < .05$), Size \times Direction ($F_{3,87} = 2.855$, $p < .05$), Axes \times Distance \times Size ($F_{12,926,374,851} = 1.935$, $p < .001$) and Distance \times Direction ($F_{2,14,62,072} = 7.766$, $p < .001$).

Pointer. As for touch input we found a significant main effect of the factor Size ($F_{3,81} = 225.564$, $p < .001$), and Distance ($F_{3,81} = 328.514$, $p < .001$). The factor Axes also had a significant main effect ($F_{3,252,87,796} = 10.723$, $p < .05$). Similar to the results for touch tasks, axes 4 ($M = 1211$ ms) and 5 ($M = 1215$ ms) were completed fastest, and axis 1 (1337 ms) slowest. Post-Hoc tests showed significant differences between axes 1 and 4, 1 and 5, and 1 and 3 ($M = 1220$ ms). We neither found interactions, nor – unlike for touch input – did we find a significant effect for Direction.

3.2 Pointing Offset

Regarding the results for pointing offset during our study (RQ1), one has to keep in mind that participants were primarily asked to point as fast as possible. We acknowledge that our results can only provide an indication regarding the effects on pointing precision in terms of offset, and that this topic will require further studies. Nevertheless, we think it can help to optimize the size and position of interactive areas for common tasks like pressing a button. That said, we analyzed PO in two ways: across all target sizes (all) and only for the smallest targets (smt) to eliminate the obvious larger offset results for larger targets. We define PO as the Euclidean distance in pixels (px) of the participants' input from the target's center.

Touch. The Axes had a significant main effect (all: $F_{5,145} = 5.619$, $p < .001$; smt: $F_{5,145} = 3.741$, $p < .05$). Through a post hoc test, we found significant differences (all) between axes 3 ($M = 15.105$ px (0.64 cm)) and 5 ($M = 13.531$ px (0.57 cm)); $p < .05$) and 6 ($M = 13.957$ px (0.59 cm), $p < .001$) and also between (smt) axes 5 ($M = 11.046$ px (0.47 cm)) and 1 ($M = 12.492$ px (0.53 cm)). We also found a significant main effect for Distance (smt: $F_{3,87} = 11.283$, $p < .001$), and a significant Direction \times Distance interaction (all: $F_{3,87} = 35.992$, $p < .001$, smt: $F_{3,87} = 19.667$, $p < .001$) as well as an Axis \times Distance (smt: $F_{15,435} = 2.597$, $p < .001$), and an Axis \times Direction interaction (smt: $F_{5,145} = 2.49$, $p < .05$). Post-hoc tests revealed that participants' pointing offset in the lower part of the vertical display area is smaller than on the horizontal area near the display connection ($p < .05$).

Pointer. We found no significant main effects for Axes, Distances, or Directions on pointing offset for pointer input neither across all nor for smallest target sizes. Not surprisingly, Size had a significant effect on PO ($F_{3,81} = 499.663$, $p < .001$) ranging from $M = 12.272$ px (0.52 cm, smallest size) to $M = 24.388$ px (1.03 cm, largest size).

3.3 Subjective Ratings

We used 5-point Likert scales to assess our participants' subjective ratings regarding TCT and PO. They are combined into three categories for this report: 'I disagree' ('1', '2'), 'Neutral' ('3') and 'I agree' ('4', '5').

Touch. The subjective data regarding TCT is mainly in line with our objective measures. 93% of the participants stated they performed fastest on the axes in the display's center. Concerning PO 86% of the participants found that the offset near the connection on the horizontal area was small, while only 73% considered this on the vertical area near the connection. Interestingly, measured data revealed the exact opposite. Though participants reported shoulder (53%) and arm (83%) fatigue, we found no evidence that this influenced the pointing performance.

Pointer. Looking at the ratings for the targeting speed with respect to Axes, 96% stated that they could hit the target on the two most central axes fast while only 46% stated that for the four outer axes. This is in line with our measurements (RQ2). Despite the lack of objective differences, 76% of our participants stated that trials with an upward direction could be completed fast while only 66% said so for the downward trials. This indicates that it might be harder to keep track of the pointer moving it downwards onto the horizontal area than the other way around onto the vertical area.

3.4 Predictability

We calculated the general index of difficulty (ID) of our task setup and the throughput (TP) of both input styles to assess the applicability of Fitts' Law and to review an accuracy-speed trade-off. The ID in our study ranged from 2.4 to 5.4 bits, which is within the range proposed by Soukoreff et al. [11]. The TP for touch input is 5.62 bps and 3.57 bps for pointer input. Although this shows that touch input performed better than mouse input, we cannot determine whether the differently oriented display areas lead to a better performance compared to planar displays [11]. We combined the TCT of all participants for each ID and calculated regression lines resulting in these formulas for prediction of movement time:

$$MT_{Touch} = 192.96 + 129.46 * ID; \text{ with } r^2 = 0.932$$

$$MT_{Pointer} = 199.08 + 230.04 * ID; \text{ with } r^2 = 0.985$$

They show that Fitts' Law is able to accurately predict the pointing performance for both touch and pointer input across both display areas of our setup (RQ3).

4 Discussion and Future Work

Our results show that pointing performance with both touch and pointer input across differently-oriented display areas is influenced by both a target's position and the direction of a task. Besides this, both input styles are generally predictable using Fitts' Law for tasks including perpendicular crossings of the display connection. Despite the simple task design, this still allows to identify a first set of suitable interaction areas for touch and pointer input.

We found that pointing performance with touch input is best in the center of the screen with a tendency towards the right display area. As most of our participants were right-handed, this tendency indicates that important interface elements should be placed toward the dominant hand's side of the user. Likewise, we found that touch input close to the display connection was more accurate on the vertical display area than on the horizontal one, which should be considered by application designers. Though this happens at the cost of slightly worse interaction times in this additional area, it may be reasonable to mitigate accuracy problems based on an oblique viewing and touch angle [2].

Contrary to touch input, we found only little evidence for an influence of differently-oriented display areas on pointer input performance. While pointing offset was only influenced by the target size, we found significant differences between task completion times depending on the target's position. Although only axis 1 differed significantly from all others, both outer axes performed worse than the central axes even across both input modalities. We also noticed bulged movement trajectories on the outer axes of the horizontal display area with pointer input as described by Hennecke et al. [3]. Though the understanding of this observation definitely requires additional studies we think the different results for the display areas could be caused by perspective distortion.

Our results are only directly applicable to the display setup used in the study and tasks, which cross the display connection vertically. For this reason, we plan to investigate the influence of different angles of the vertical display area as well as the task axes. Though we did not find any statistical evidence for an influence of a user's handedness, we also see the need for an additional study investigating this matter. It will be very interesting to see which of these parameters can be taken into account leading to a general Fitts' Law formula for a curved display.

References

1. Fitts, P.M.: The information capacity of the human motor system in controlling the amplitude of movement. *Journal of Experimental Psychology. General* 121(3), 262–269 (1954)
2. Forlines, C., Wigdor, D., Shen, C., Balakrishnan, R.: Direct-touch vs. mouse input for tabletop displays. In: *Proc. of CHI 2007*, pp. 647–656 (2007)
3. Hennecke, F., Matzke, W., Butz, A.: How Screen Transitions Influence Touch and Pointer Interaction Across Angled Display Arrangements. In: *Proc. of CHI 2012*, pp. 209–212 (2012)
4. MacKenzie, I., Buxton, W.: Extending Fitts' law to two-dimensional tasks. In: *Proc. of CHI 1992*, pp. 219–226 (1992)
5. MacKenzie, I., Sellen, A., Buxton, W.: A Comparison of Input Devices in Element Pointing and Dragging Tasks. In: *Proc. of CHI 1991*, pp. 161–166 (1991)
6. Micire, M., Schedlbauer, M., Yanco, H.: Horizontal Selection: An Evaluation of a Digital Tabletop Input Device. In: *Proc. of AMCIS 2007*, p. 164 (2007)
7. Nacenta, M.A., Mandryk, R.L., Gutwin, C.: Targeting across displayless space. In: *Proc of CHI 2008*, pp. 777–786. ACM, New York (2008)
8. Nacenta, M.A., Sallam, S., Champoux, B., Subramanian, S., Gutwin, C.: Perspective cursor: perspective-based interaction for multi-display environments. In: *Proc. of CHI 2006*, pp. 289–298 (2006)
9. Po, B.A., Fisher, B.D., Booth, K.S.: Mouse and touchscreen selection in the upper and lower visual fields. In: *Proc. of CHI 2004*, pp. 359–366 (2004)
10. Sasangohar, F., MacKenzie, I.S.: Evaluation of mouse and touch input for a tabletop display using Fitts' reciprocal tapping task. In: *Proc. of HFES 2009*, pp. 839–843 (2009)
11. Soukoreff, R.W., MacKenzie, I.S.: Towards a standard for pointing device evaluation, perspectives on 27 years of Fitts' law research in HCI. *International Journal of Human-Computer Studies* 61(6), 751–789 (2004)
12. Voelker, S., Sutter, C., Wang, L., Borchers, J.: Understanding flicking on curved surfaces. In: *Proc. of CHI 2012*, pp. 189–198 (2012)
13. Weiss, M., Voelker, S., Sutter, C., Borchers, J.: BendDesk: Dragging Across the Curve. In: *Proc. of ITS 2010*, pp. 1–10 (2010)
14. Wellner, P.: The DigitalDesk calculator: tangible manipulation on a desk top display. In: *Proc. of UIST 1991*, pp. 27–33 (1991)
15. Wimmer, R., Hennecke, F., Schulz, F., Boring, S., Butz, A., Hußmann, H.: Curve: Revisiting the Digital Desk. In: *Proc. of NordiCHI 2010*, pp. 561–570 (2010)